

Computação Quântica

Para Administradores de Rede

Jessian Ferreira Cavalcanti <jessian@nic.br>

RFC 9340

Architectural Principles for a Quantum Internet

RFC 9583

Application Scenarios for the Quantum Internet

<https://mailman.irtf.org/mailman/listinfo/qirg>

<https://www.open-qkd.eu/tutorial>

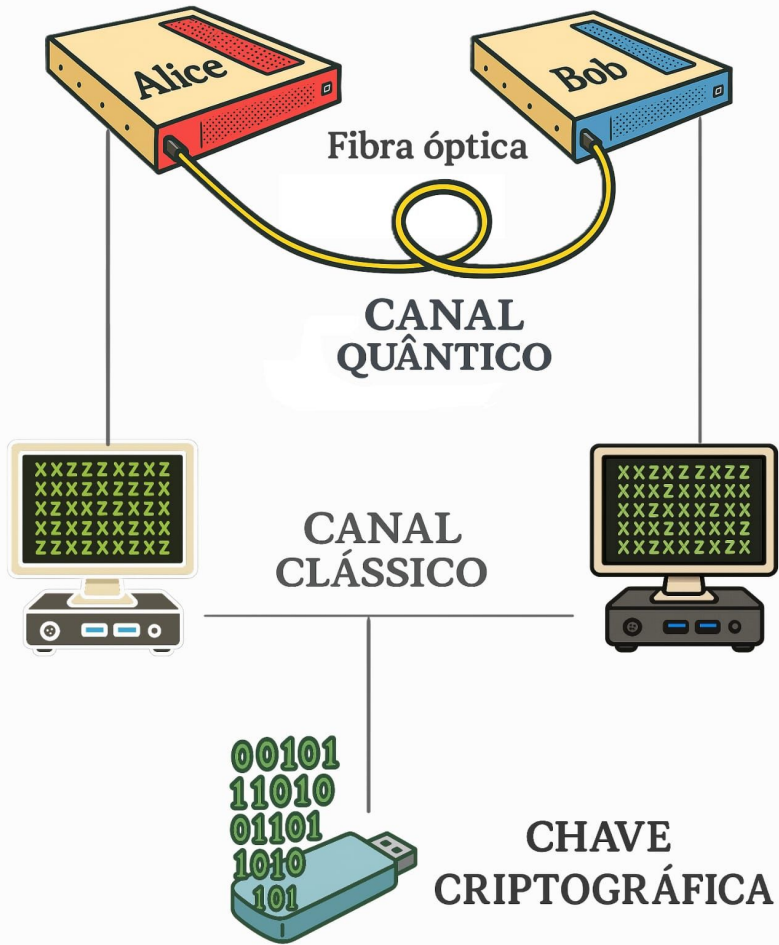

Alice

Bob

Fibra óptica

CANAL QUÂNTICO

CANAL CLÁSSICO

CHAVE CRIPTOGRÁFICA

00101
11010
01101
1010
101

XXZZXZXZ
XXXZXXZX
XZXZZXZX
XZXZXZX
ZZXZXZXZ

XXZZXZXZ
XXXZXXZX
XZXZXZX
XXXZXXZX
XZXZXZX

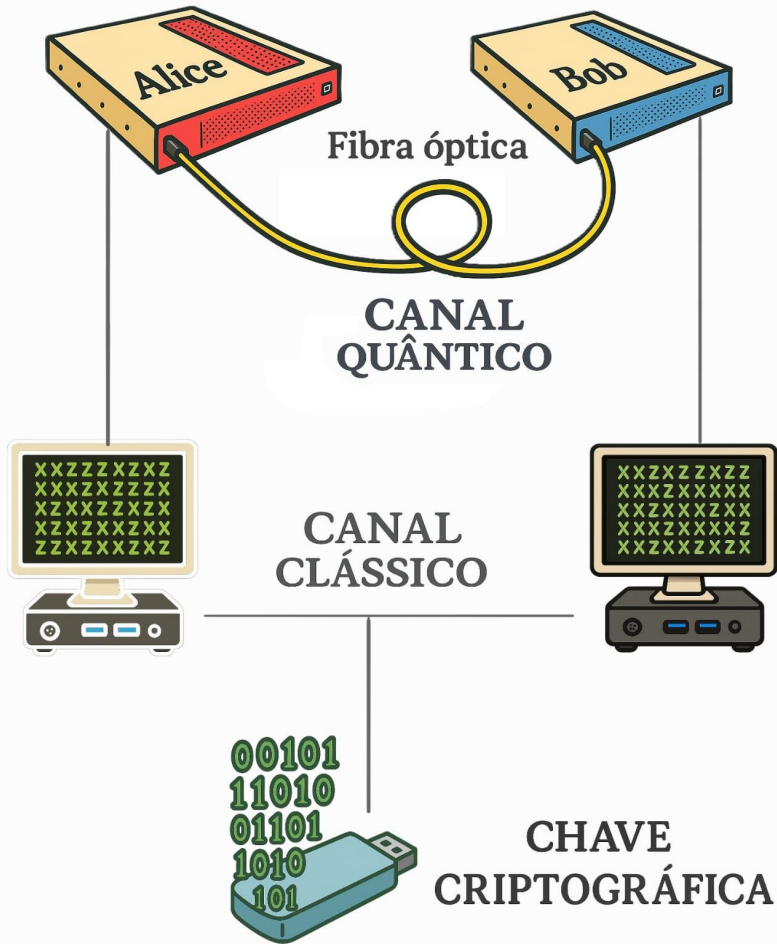

<https://open-qkd.eu/>

RFC 9340

Here, "qubit" refers to a physical implementation akin to what a flip-flop, switch, voltage, or current would be for a classical bit.

Qual o limite para simular um computador quântico?

Cada 10 qubits correspondem a 2^{10} x 64 bits

2^{10} corresponde a 1024

Portanto 2^{20} ~1 M, 2^{30} ~1G, 2^{40} ~1T

Multiplicado por 64 bits (ou 8 bytes)

RFC 9340

Entanglement Swapping

The problem with generating entangled pairs directly across a link is that efficiency decreases with channel length. Beyond a few tens of kilometres in optical fibre or 1000 kilometres in free space (via satellite), the rate is effectively zero, and due to the no-cloning theorem we cannot simply amplify the signal. The solution is entanglement swapping [Briegel98].

Fidelity

To describe the quality of a quantum state, a physical quantity called fidelity is used [NielsenChuang].

Fidelity takes a value between 0 and 1 -- higher is better, and less than 0.5 means the state is unusable.

RFC 9340

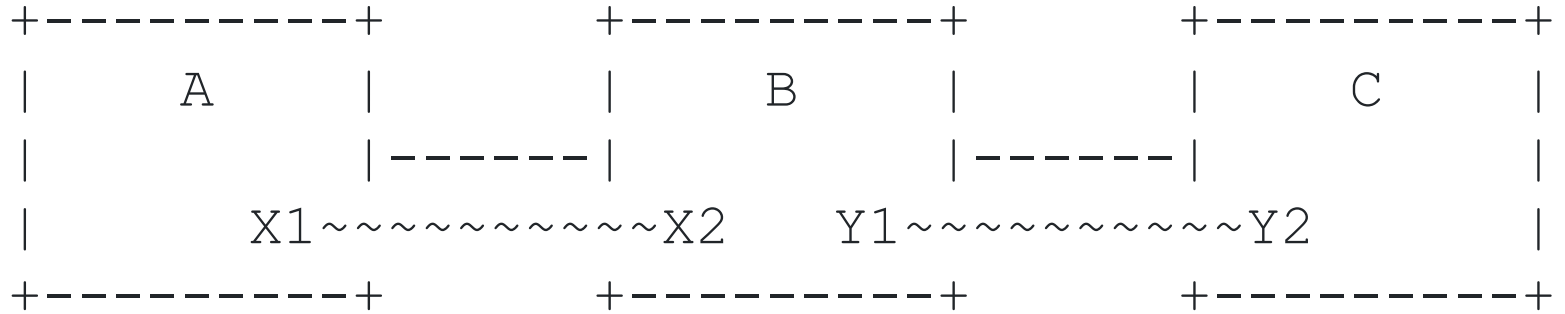

<https://thequantumlaend.de/>

<https://thequantumlaend.de/quantum-circuit-designer/>

<https://tiangongqs.com/>

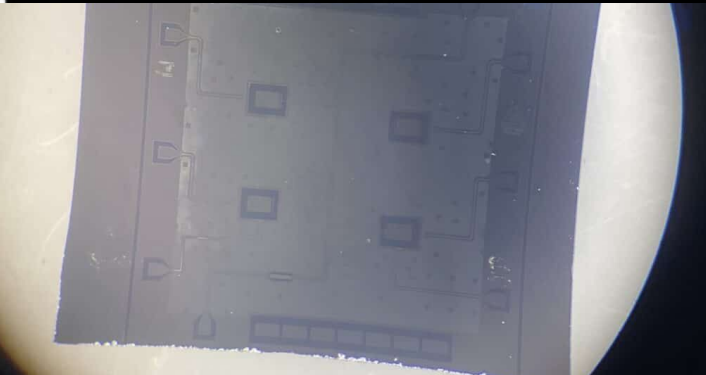
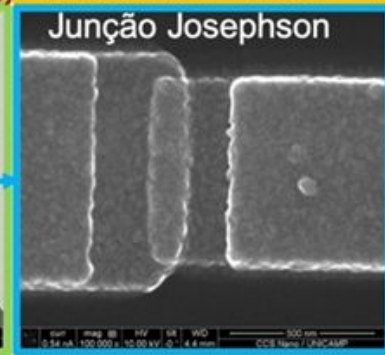
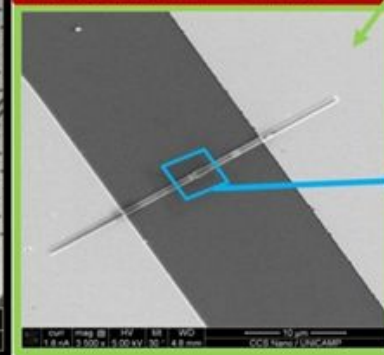
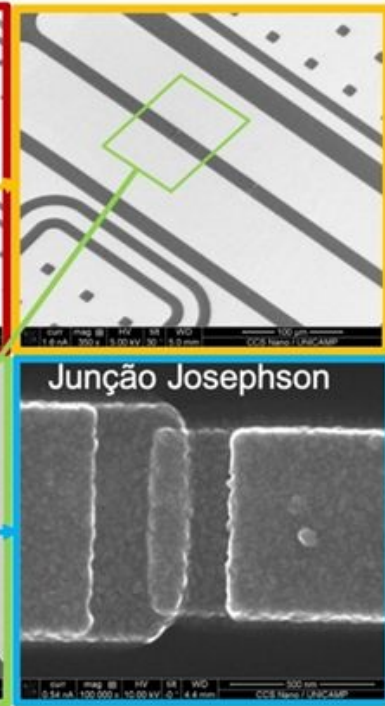
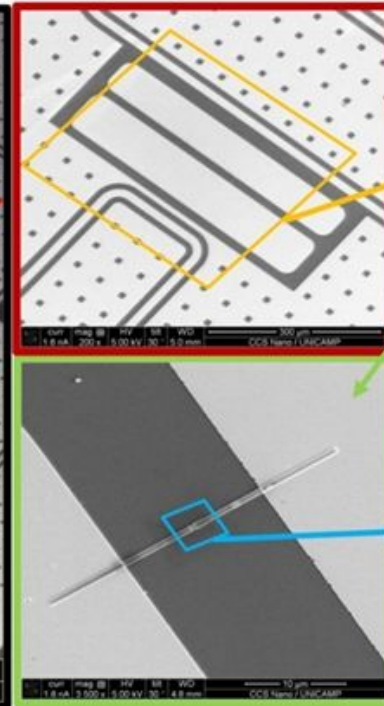
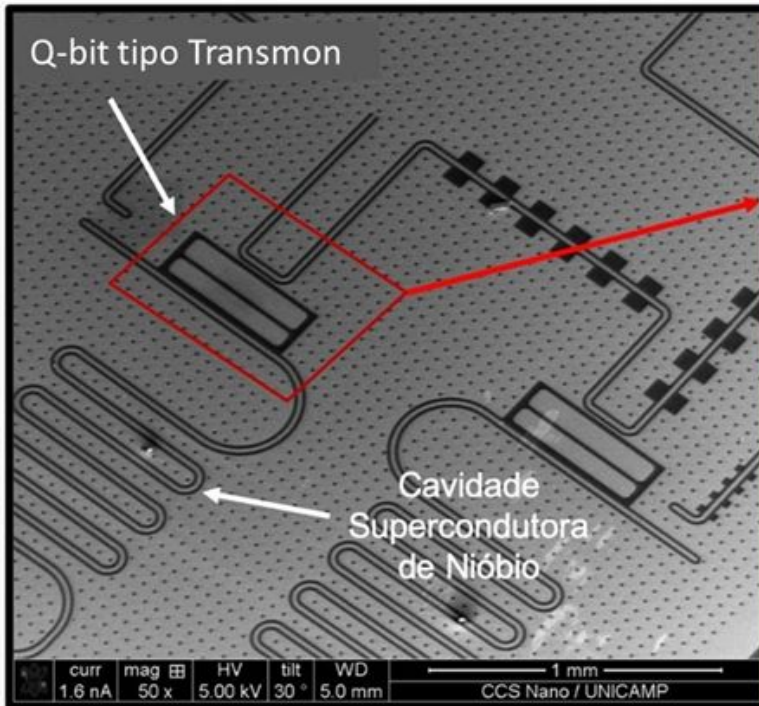

CBPF
Unicamp